

BX616

Portable Multi-gas Detector Using Manual



1. Brief Introduction

BX616 portable multi-gas detector could detect combustible gas, O₂ and other two types toxic gases continuously and simultaneously. It is widely used in the area where explosion-proof is required or toxic gas leaks, like underground channels or mining industry, so as to protect the workers' life and avoid damage on the relevant equipments.

2. Main features

- Natural diffusion sampling method and high-sensitivity sensor, with high sensitivity and repeatability.
- 32-bit built-in MCU, high reliability and self-adaptation ability.
- Full functions, easy operation.
- CSTN colorful LCD, more intuitionistic, abundant and clear indication.
- Compact design, easy carrying.
- High strength engineering plastics and compound anti-slippery rubber; high strength, water-proof, dust-proof and explosion-proof.

3. Technical Data

Target Gas	Detecting Range	Low-alarm range	High-alarm range	Default low alarm	Default high alarm	TWA Alert	STEL Alert
CH ₄	0~100%LEL	10%LEL~25%LEL	25%LEL~80%LEL	20%LEL	50%LEL		
H ₂ S	0~100ppm	5ppm~15ppm	15ppm~30ppm	10ppm	15ppm	10ppm	15ppm
CO	0~1000ppm	25ppm~100ppm	100ppm~500ppm	35ppm	200ppm	35ppm	200ppm
O ₂	0~30%vol	16%vol~19.5%vol	22.5%vol~24%vol	19.5%vol	23.5%vol		

Gas sampling method: natural diffusion

Gas sensor type: Catalytic(for combustible gas) and electrochemical (for H₂S, CO and O₂)

Detecting gas: Combustible gas, H₂S, CO, O₂

Accuracy: $\leq \pm 5\%$ F.S.

Response Time: $\leq 30s$

Indication: LCD displays real-time and system status;
LED, audio and vibration alert for gas leakage, fault and low voltage.

Working environment: $-20^{\circ}C \sim 50^{\circ}C$, $< 95\%RH$ (no dew)

Power Source: DC3.6V Li-on battery, 1800mAh

Charging time: $\leq 6h$

Working time: $\geq 8h$ continuously (without alarming)

Gas Sensor Life: 2 years

Explosion-proof grade: ExiadIICT3

Protection Grade: IP65

Weight: Appr. 200g (with battery)

Dimensions: 116mm×66mm×30mm(L × W × H)

4. Structure & Function

4.1 Appearance

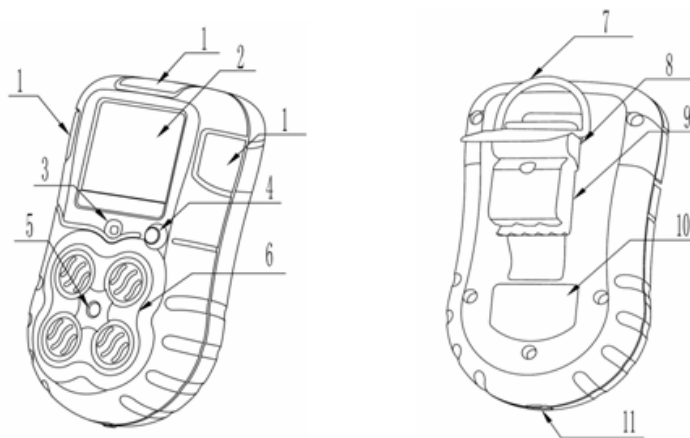
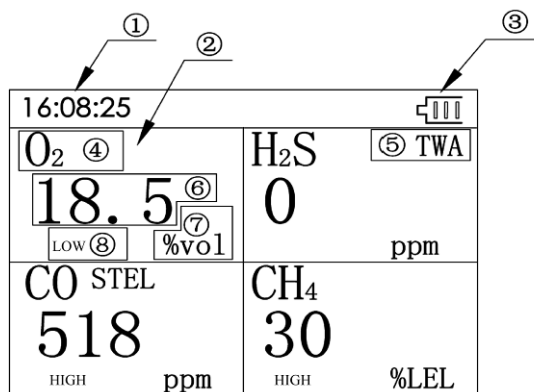

Figure 1

No.	Name	No.	Name
1	Alarm light	7	Hang ring hole
2	LCD screen	8	Buckle
3	Buzzer	9	Alligator clip
4	Power on/off button	10	Label
5	Calibration hole	11	Charging/Communication port
6	Detection window		

4.2 Indication information



No.	Function	No.	Function
1	Time	5	TWA or STEL alert
2	Detecting gas	6	Gas concentration
3	Battery indication	7	Unit
4	Gas type	8	H-alarm or L-alarm

Figure 2

4.3 Button function

Button	Functions
	<ul style="list-style-type: none"> ● Turn on: Press it for 1s, the detector is power on. ● Turn off: Press it for more than 3s, the detector is power off. ● Muffle: When alarming, press it once and the audio alarming will be off. ● Quit libration: When alarming, after audio alarming is off, press it once and shaking alarming is off. ● Detector status checking: When the detector is in the status of detection, press it to check max. gas level, min. gas level, STEL, TWA, current time, serial number and version number. ● Calibration: When the detector enters detection menu, press it continuously even the screen is closed. After 10 seconds, when the screen is open again and it shows calibration status, then you can release it and to calibrate the device.

5. Operation instruction

5.1 Turn on

Press the button for 1s and then release it. After the buzzer gives short sound once, the detector is turned on. On the screen, it displays in turns "Welcome", "Warm up", "Self test", "High alarm", "Low alarm", "STEL", "TWA". After that, it enters detecting status. At this time, it displays the concentration of O₂, H₂S, CO and Combustible gas in the environment.

Note: If the detector is set to auto zero calibration after turning on, then the user should turn on the detector in the clean air. Otherwise, the user should be responsible for the testing result. When the detector leaves the factory, it is set to auto zero calibration after turning on.

5.2 Turn off

Under power on status, press power on/off button for more than 3s, the buzzer gives short sound twice and long sound once. After that, the detector will be power off.

5.3 Alarming

(1) When the gas concentration reaches the presetting alarming levels, the detector will give relative alarming: the LED light twinkling, vibrating, and buzzing. The user can cancel audio and shaking alarming by press the power on/off button: the first press to cancel audio alarming④, and the second to cancel vibrating⑤.

(2) When the detector is turned on and kept under the environment with the target toxic gas, if the gas concentration is more than the maximum average level of TWA or STEL, the detector will give TWA or STEL alert. At this time, the user can also cancel the audio and shaking alarming by pressing the power on/off button as above Section (1).

Besides, the detector will make alarming sound when its sensor meets fault or at low battery status. Please refer to the LCD display for details.

Note: ④ and ⑤ are available only when these functions are activated in the scene mode.

5.4 Working status checking

When there is no alarm in the detection status, or the alarms are canceled in the alarming status, press the power on/off button by time, the LCD screen will display max. gas level and min. level⑥, STEL⑦, TWA⑦, current time, serial number(SN) and version number(VER) in turn.

Notes: ⑥ Only O₂ sensor has such indication.

⑦ Only toxic gas sensors have STEL and TWA alert.

5.5. Calibration

When the detector is under power on status, keep pressing the power on/off button even the tester is power off. After 10 seconds, the LCD screen will display again and it enters calibration mode, then lease the power on/off button. After warming up, the detector begins zero calibration firstly. Please put the detector into the clean air environment. When the screen displays the calibration level, please inject the standard gas into the tester like the indication of the following picture. The detector will automatically analyze the gas and process the calibration. After calibration, the screen will display the calibrated gas name and relative items. If need to make other gases' calibration, please repeat the above process.

If need to calibrate different gases in the same time, please inject different standard gases and follow the above procedures, the tester will make the calibration automatically, too.

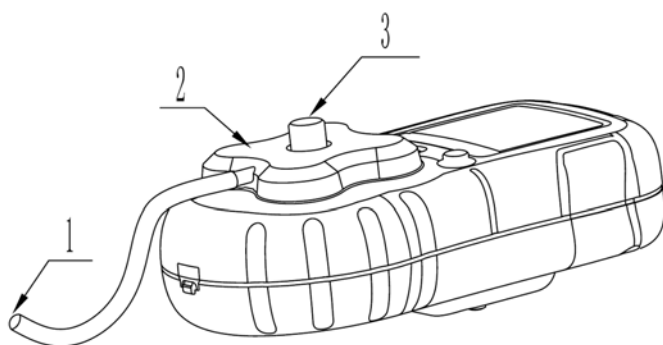

No.	Name
1	Gas input hole
2	Calibration map
3	Screwing nut

6. Data upload

Connect the detector to computer through the data cable (Min USB terminal connects to the interface on the bottom of the detector, and DB9 terminal connects to COM port of computer). Turn on the tester and run the software. Then you can choose to upload the testing record to the computer. Please refer to the using manual of the software for more details.

7. Charging

Please charge the detector when it shows low battery or the detector can't be turned on due to low battery. Before charging, please turn off the detector. After you connect the charger correctly between the detector and AC power source, the detector will be turned on automatically. On the screen, battery indication will show you how much the battery is charged. When the battery mark on the screen is full and doesn't change any more, it means the charging is completed. Please pull off the charger.

Warning: During charging status, the detector can't detect the gas leakage. Please do not try to charge it at testing places to avoid fire or explosion. Please do not charge it when the detector is working to avoid potential damage.

8. Using and replacement of the gas sensor

The detector adopts gas sensor module. Please pay attention to the life of the gas sensor and replace it in time. In order to assure the accuracy of the gas sensor, please calibrate it every half year.

For replacement, we only send out separate gas sensor and calibration file. You can replace the old gas sensor, and then write the calibration program into the detector's MCU through our software. After that, replacement is completed.

9. Possible fault and corresponding solution

Possible fault	Possible reason	Corresponding solution
The detector can't be turned on	Too low battery	Please charge it in time.
	The detector dies	Please contact the manufacturer of dealer
	Fault of electric circuit	Please contact the manufacturer of dealer
No response to the gas	Warm up is not finished	Wait till warm up is finished
	Fault of electric circuit	Please contact the manufacturer of dealer

Inaccurate indication	Sensor is overdue	Please contact the manufacturer or dealer to replace the gas sensor
	Uncalibrated for long time	Please calibrate it in time
Fault indication of time	Battery voltage is used up	Please charge it and reset time
	Strong electromagnetism disturb	Please reset time
Zero calibration is unavailable	Too much zero drift of gas sensor	Please calibrate or replace the gas sensor
Minus gas level displayed	Gas sensor drift	Calibrate zero point
Sensor fault indication	Sensor fault	Please contact the manufacturer or dealer to replace the gas sensor

10. Notices

- 10.1 Falling down from high places or strong shake is prohibited.
- 10.2 The detector may not work properly at interferential high-concentration gas.
- 10.3 To avoid incorrect result or possible damage to the detector, please operate and handle the detector in accordance with the manual.
- 10.4 The detector should be not stored or used neither under the circumstance with caustic gas (such as Cl₂), nor under the other rugged circumstances, including excessive high or low temperature, high humidity, electromagnetic field and strong sunshine.
- 10.5 If there is dust on the surface of the detector after a long-term use, please clean it lightly with clean soft cloth. The surface may be scraped or destroyed with caustic solvent or hard things.
- 10.6 To assure the testing accuracy, the detector should be calibrated periodically. And the calibration period should be less than one year.
- 10.7 Please put the used Lithium batteries to the appointed places or send to our company. Don't discard them into the dustbin at random.

11. Standard accessories:

Charger 1pc
 Calibration cap 1pc
 Communications cable 1pc
 CD driver 1pc
 User manual 1pc
 Relative portable accessories 1set